

ENDO KOGYO INDIA PVT. LTD.

GENERAL CATALOGUE



ENDO
ENDO KOGYO CO., LTD.
〒959-1261 3-14-7 Akiba-cho,
Tsubame, Niigata, Japan
P2K300

5-7 kg
ENDO SPRING BALANCER

CE



Model
EWS-7

Capacity 5.0-7.0 kg

Cable travel 1.3m

Year of manufacture

ENDO KOGYO CO., LTD.

〒959-1261 3-14-7. Akiba-cho,
Tsubame, Niigata, Japan

MADE IN JAPAN

SPRING BALANCER



ENDO Spring Balancers are a valuable addition to your assembly shop, body shop and many other industries. They support heavy tools with cable tension equal to the weight of the suspended tools, which makes them seem virtually "weightless". The assembler has the flexibility to reposition the tool, while experiencing comfortable operation and less fatigue.

Advantages

- Help the assembler with repetitive tasks such as installing fasteners: screws, nuts, bolts, etc. Hold fixtures, tools, welding guns, and similar equipment.
- Improves efficiency and diminishes worker fatigue.
- Stabilizes tool positioning and contributes to work accuracy.
- Contributes to a safer working environment. Keeps fixtures, tools, and welding guns off of the floor and clean.
- Eliminates the need to separately power the balancer.



Fall Arrest Device



Secondary Support Hanger



Gauge



Drum Lock System



Cartridge Spring



Wire Rope Replacement

LIGHT CAPACITY



EK, ERP

STANDARD



EW,
EWS, EWF

LONG STROKE



ELF

Model	Capacity (kg)	Stroke (m)	Mass (kg)
EW-3	1.0 - 3.0	1.3	1.4
EW-5	2.5 - 5.0	1.3	1.5
EWS-3	1.5 - 3.0	1.3	1.9
EWS-5	3.0 - 5.0	1.3	2.1
EWS-7	5.0 - 7.0	1.3	2.1
EWF-9	4.5 - 9.0	1.3	3.5
EWF-15	9.0 - 15.0	1.3	3.8
EWF-22	15.0 - 22.0	1.5	7.3
EWF-30	22.0 - 30.0	1.5	7.7
EWF-40	30.0 - 40.0	1.5	9.7
EWF-50	40.0 - 50.0	1.5	10.1
EWF-60	50.0 - 60.0	1.5	11.1
EWF-70	60.0 - 70.0	1.5	11.4
EWF-90	70.0 - 90.0	2.0	21.9
EWF-105	85.0 - 105.0	2.0	24.0
EWF-120	100.0 - 120.0	2.0	27.5
EWF-160	120.0 - 160.0	1.8	28.3
ETP-14	120.0 - 140.0	1.2	24.1
ETP-15	140.0 - 170.0	1.2	28.7
ETP-16	170.0 - 200.0	1.2	29.7

Model	Capacity (kg)	Stroke (m)	Mass (kg)
EK-00	0.5 - 1.5	0.5	0.2
EK-0	0.5 - 1.5	1.0	0.5
ERP-06E	0.3 - 0.6	1.5	0.4
ERP-1E	0.5 - 1.0	1.5	0.4
ERP-2E	1.0 - 2.0	1.5	0.4
Model	Capacity (kg)	Stroke (m)	Mass (kg)
ELF-3	1.5 - 3.0	2.5	4.6
ELF-5	3.0 - 5.0	2.5	4.8
ELF-9	5.0 - 9.0	2.5	5.4
ELF-15	9.0 - 15.0	2.5	10.0
ELF-22	15.0 - 22.0	2.5	10.2
ELF-30	22.0 - 30.0	2.5	11.0
ELF-40	30.0 - 40.0	2.5	14.5
ELF-50	40.0 - 50.0	2.5	14.9
ELF-60	50.0 - 60.0	2.5	17.1
ELF-70	60.0 - 70.0	2.5	18.0

LARGE CAPACITY



ETP

TOOL HOSE BALANCER



THB

AIR TOOL REEL



ATR

TORQUE REEL



ER

SPRING BALANCER WITH SNAP BACK PREVENTION



EWA

BRAKING BALANCER



EWF-B

BALANCER FOR ENGINE ASSEMBLY



EWF-C

CLEAN ROOM BALANCER

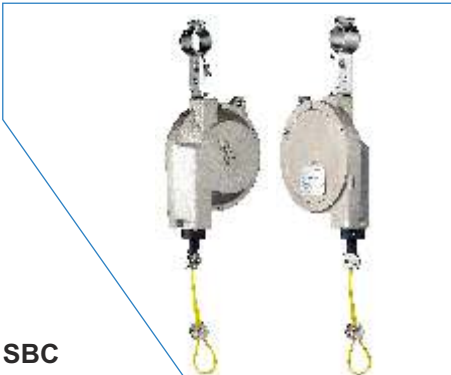

SBC

SQUARE BALANCER

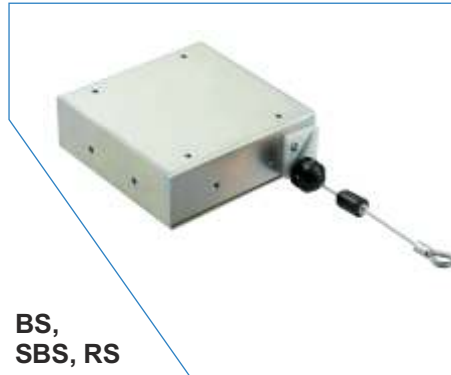

BS,
SBS, RS

COUNTER REACTION BALANCER

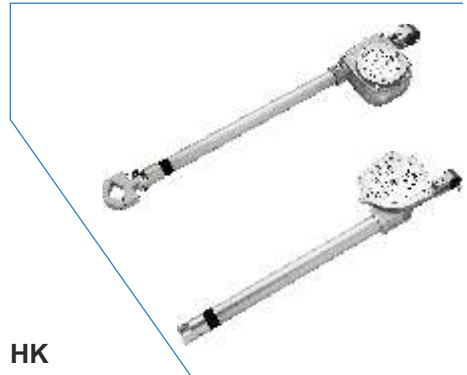

HK

Model	Capacity (kg)	Stroke (m)	Air Inlet (φ mm)	Mass (kg)
THB-15	0.5 - 1.5	1.3	8.5	1.9
THB-25	1.5 - 2.5	1.3	8.5	2.0
THB-35	2.5 - 3.5	1.3	8.5	2.1
THB-50	3.5 - 5.0	1.3	8.5	2.1
THB-65	5.0 - 6.5	1.3	8.5	2.2

Model	Max. Tension (N)	Stroke (m)	Air Inlet (φ mm)	Mass (kg)
ATR-5	49	2.0	10.0	3.8
ATR-5-1	49	2.0	10.0	4.2

Model	Max. Initial Tension (N)	Active Cable Travel (m)	Effective Spring Turns	Mass (kg)	With Ratchet
ER-3A	18	3	(Approx) 16	1.4	✓
ER-3B	18	3	(Approx) 16	1.3	
ER-5A	25	3	(Approx) 13	1.5	✓
ER-5B	25	3	(Approx) 13	1.4	
ER-10A	49	4	(Approx) 13	4.5	✓
ER-10B	49	4	(Approx) 13	3.8	

Model	Capacity (kg)	Stroke (m)	Mass (kg)
EWA-15	9.0 - 15.0	1.5	4.7
EWA-22	15.0 - 22.0	1.5	8.9
EWA-30	22.0 - 30.0	1.5	9.3
EWA-40	30.0 - 40.0	1.5	11.9
EWA-50	40.0 - 50.0	1.5	12.3
EWA-60	50.0 - 60.0	1.5	13.3
EWA-70	60.0 - 70.0	1.5	13.6

Model	Capacity (kg)	Stroke (m)	Mass (kg)
EWF-3B	1.5 - 3.0	1.3	4.7
EWF-5B	3.0 - 5.0	1.3	8.9
EWF-7B	5.0 - 7.0	1.3	9.3

Model	Capacity (kg)	Stroke (m)	Mass (kg)
EWF-3C	1.5 - 3.0	1.3	1.7
EWF-5C	3.0 - 5.0	1.3	1.9
EWF-7C	5.0 - 7.0	1.3	1.9

Model	Capacity (kg)	Stroke (m)	Mass (kg)
SBC-15-C	0.5 - 1.5	1.0	1.2

Model	Capacity (kg)	Stroke (m)	Mass (kg)
EBS-155150	0.5 - 1.5	1.0	1.3
BS3W	1.5 - 3.0	1.3	2.2
BS5W	3.0 - 5.0	1.3	2.4
BS7W	5.0 - 7.0	1.3	2.4
BS3N	1.5 - 3.0	1.3	2.2
BS5N	3.0 - 5.0	1.3	2.4
BS7N	5.0 - 7.0	1.3	2.4
SBS3W	1.5 - 3.0	0.5	0.8
SBS5W	3.0 - 5.0	0.5	0.8
SBS3N	1.5 - 3.0	0.5	0.8
SBS5N	3.0 - 5.0	0.5	0.8

Model	Max. Tension (N)	Stroke (m)	Mass (kg)
RS3W	29.4	3.0	2.0
RS5W	49.0	3.0	2.1
RS3N	29.4	3.0	2.0
RS5N	49.0	3.0	2.1

Model	Capacity (kg)	Stroke (m)	Max. Torque (Nm)	Mass (kg)
HK04310	0.5 - 3.0	1.0	40	3.8
HK04305	0.5 - 3.0	0.5	40	3.5
HK15510	2.5 - 5.0	1.0	150	6.2
HK15505	2.5 - 5.0	0.5	150	5.3

AIR BALANCER



ENDO Air Balancers provide very precise weight lifting capabilities, with more accurate positioning than can be achieved with an air hoist. ENDO Air Balancers are used for assembly lines where precision load positioning is required.

- Speed Adjustment** : Speed control valve equipped on the pendant control (MS).
- Floating Condition** : Approx 30cm floating condition for precise position setting (MS, MS-A, MS-AG, MS-ATC).
- Down Stop** : Added safety measure, a suspended load will not fall even if the air supply is cut off or when hoses are broken (except MS).
- Energy Saving** : Air consumption of air balancer is only 1/7 of that of air hoist (comparing our existing model).
- Cleanness** : No lubrication is required and produces no oil mist.
- Inertia Prevention Unit** : Eliminates bouncing of a suspended load (EHB-85D MSD). Patent No. (JP)2008-284586



EHB-85 MS



EHB-85 ABC-5G-B

Body	Capacity (kg)	Stroke (m)	Wire Rope/Chain Size (mm)	Air Inlet	Mass (kg)
EHB-50	55	1.9	4.76	Rc 3/8	28
EHB-85	90	1.9	4.76	Rc 3/8	29
EHB-85C	90	1.9	4.00	Rc 3/8	30
EHB-85D MSD	90	1.9	4.76	Rc 3/8	40
EHB-130	140	1.9	4.76	Rc 3/8	36
EHB-130C	140	1.9	4.00	Rc 3/8	37
EHB-270	270	1.9	4.76	Rc 3/8	43

Control Module	Function
MS	Hoisting
MS-A	Hoisting with Down Stop
MS-AG	Hoisting with Down Stop by Grip Handle
MS-ATC	Hoisting by Grip Handle
BC2	Dual Balance
BC1	Single Balance
ABC-5P-B	Automatic Balancing
ABC-5G-B	Automatic Balancing by Grip Handle
MSD	Hoisting with Inertia Prevention Unit

- ABC, BC1, BC2 are not available with EHB-270.
- The air inlet size for BC1 Control Module is Rc 1/4.

- Capacity mention above are with air pressure 7 BAR.
- EHB Air Balancer can be used with Air Pressure 4-7 BAR (3-5 BAR for ABC Control Module).



Top Hook



I-Beam Trolley



ENDO Air Hoists can provide a better solution than electric hoists:

- Easy Handling** : Due to the small, compact but powerful hoist bodies
- Improved Working Efficiency** : The "run-time" and "number of starts" are unlimited.
Especially with repeat lift jobs due to ENDO's high speed operation and lack of over-heating issues.
- Able to do Precise Work** : ENDO air hoists use non-step (continuously variable) speed controls that eliminate rough stops and starts.
- Easy Installation** : The air hoist works immediately upon connecting the air hose. Always make sure that you have F.R.L. Unit before you connect the air hoist.
- Hazardous Duty** : Ideal for use in hazardous environments, such as chemical plants.
- Overload Protection** : ENDO provides built-in overload protector for capacity above 250kg.
- Spark Proof Model** : Spark Proof Models are available upon request.
- ATEX Classification** :  II2G/DIIBT5 (EHW, AT, EHL-025TS/05TS/1TW/1TS/2TW)
 II2G/DIIBT4 (EHL-3TS/6TW)



WIRE ROPE HOIST



EHW

CHAIN HOIST



AT, ATC

CHAIN HOIST



EHL + PCS

AIR MOTOR TROLLEY



MTH + EHL

Model	Capacity	Lifting Speed (m/min)	Stroke (m)	Chain / Wire Rope (mm)	Air Intel	Mass (kg)
EHW-60R	60kg	26.0	1.9	4.76	Rc 3/8	9.5
EHW-120R	120kg	16.0	1.9	4.76	Rc 3/8	9.7
AT-60K	60kg	23.5	3.0	4.0 x 1	Rc 3/8	12.3
AT-125K	125kg	14.5	3.0	4.0 x 1	Rc 3/8	12.5
ATC-60K	60kg	20.0	2.0	4.0 x 1	Rc 3/8	14.3
ATC-125K	125kg	12.0	2.0	4.0 x 1	Rc 3/8	14.5
EHL-025TS PCS-1	250kg	18.0	3.0	6.3 x 1	Rp 1/2	21.0
EHL-05TS PCS-1	500kg	10.5	3.0	6.3 x 1	Rp 1/2	21.0
EHL-1TW PCS-1	1 t	5.2	3.0	6.3 x 2	Rp 1/2	26.5
EHL-1TS PCS-2	1 t	6.0	3.0	7.1 x 1	Rp 1/2	36.7
EHL-2TW PCS-2	2 t	3.0	3.0	7.1 x 2	Rp 1/2	44.7
EHL-3TS PCS-2	3 t	3.0	3.0	12.5 x 1	Rp 3/4	77.7
EHL-6TW PCS-2	6 t	1.5	3.0	12.5 x 2	Rp 3/4	98.7
Air Motor Trolley	Capacity	Travel Speed (m/min)	Beam Width (mm)	Min. Curve Radius (mm)	Air Intel	Mass (kg)
MTH-1T-5	1 t	28.0	75 / 100 / 125	3,500 / 800	Rc 1/2	35.0
MTH-2T-5	2 t	18.0	125 / 150	1,000	Rc 1/2	63.0
MTH-6.3T	6.3 t	19.0	150 / 175 / 190	2,500	Rc 3/4	127.0

- Speed mentioned above is with Air Pressure 6 BAR.
- Air Hoist can be used with Air Pressure 4-6 BAR.
- The lifting speed is measured with related load.

Emergency Stop Button



Upon Request

Overload Protector



Upon Request

ALUMINIUM / STEEL RAIL SYSTEM



Power Free rail system is totally different from the conventional electric hoist in operation mechanism. It can be moved left and right with power freely. Endo Rail System is a proven system and efficient solution for variety of overhead material handling requirement for auto and engineering industry. Endo Rail System is used for handling and assembling of heavy material in three dimensional work space without difficulty. The operator does not feel fatigue in handling heavy material which results in enhancement of production to great extent. The system is composed of units so that system layout can be made without restriction. The unit parts can be reutilized when the line was modified.



	Code	Part Name	Length (m)	Approx Weight (kg)	Allowable Load (kg)
UTA - I	UTA-I-01-01000	Aluminum Track	1	5.66	500
	UTA-I-01-02000	Aluminum Track	2	11.32	130
	UTA-I-01-03000	Aluminum Track	3	16.98	120
	UTA-I-01-04000	Aluminum Track	4	22.64	110
	UTA-I-01-05000	Aluminum Track	5	28.30	107
	UTA-I-01-06000	Aluminum Track	6	33.96	105
UTA - II	UTA-II-01-01000	Aluminum Track	1	11.80	2,600
	UTA-II-01-02000	Aluminum Track	2	23.60	2,300
	UTA-II-01-03000	Aluminum Track	3	35.40	1,000
	UTA-II-01-04000	Aluminum Track	4	47.20	590
	UTA-II-01-05000	Aluminum Track	5	59.00	380
	UTA-II-01-06000	Aluminum Track	6	70.80	220

JIB CRANES / INDUSTRIAL MANIPULATORS

Jib Cranes

Endo Jib crane is used in conjunction with a cable balancer or chain hoist to provide an inexpensive method of material handling. It is beneficial when the rigidity of a manipulator is not needed or when limited vertical travel is required.

Manipulators

Pneumatic Manipulators, can be used to effortlessly lift, move, turn and position any off-set load up to 200 kgs. They are reliable, robust and versatile in their operation and are available to suit every requirement. Once the machine is calibrated the operator may simply use manual movement to effortlessly guide product.



ENDO Cable Reel has been using in various industrial markets in the world. The experience and know-how obtained from Spring Balancer enable ENDO Cable Reel to achieve long life cycle of a product and ideal for harsh environmental application or equipment requires high frequency of operation.

Cable Reel is designed and manufactured as per customer's requirement.



SPRING TYPE



CRF

CRL

CRE

MOTOR TYPE



Torque Motor

Contorq Motor

Inverter-driven Motor

Servomotor

HOSE REELS

For clean and safety working place.

- Spring-rewind mechanism.
- Latching system.
- Max. 20m hose - max. 15mm ID.
- Plastic casing & Steel Casing.
- Swiveling or fixed wall-bracket.
- Mountable in every position.
- Medium: Water, Air, Greese, Foods, Gas, oil, grease & Pesticides.



ELECTRIC CHAIN HOISTS & MANUAL HOISTS

Electric Hoist:

- Rated Capacity : Single Speed 250 Kg To 20 t
Dual Speed 250 kg To 5 t
- Voltage: 415 V/ 230 V- 50/60 HZ
- Suspension varieties: Motorised trolley, Geared or plain trolley.
- Smooth operation.
- High quality & advance safety mechanism.
- Easier maintenance.

Manual Chain Hoist:

- H-50A Series
- Rated Load: 500 Kg To 50 t
- Compact, light, and easy to use and operate

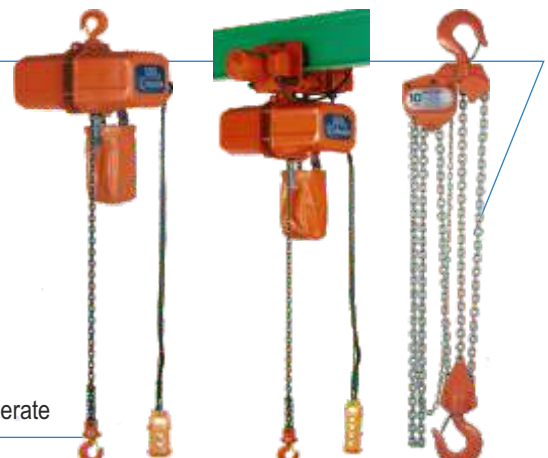

CRUSHER

SMALL BIAXIAL



LARGE BIAXIAL



UNIAXIAL



SELF LOCK

SAVE FROM FALLING

Save your life from falling. Work at high places is always risky. Self Lock enables safe and flexible work in high places. It helps your high performance at public works, construction sites, shipbuilding, bridge site and electrical works etc.

FOR HUMAN

Model	Capacity (kg)	Rope Length (m)	Standard Accessory
SL-7H	30 - 120	7	Shackle Sling Rope
SL-10H	30 - 100	10	
SL-17H	30 - 120	17	
SL-25L	30 - 100	25	
SL-30H	30 - 120	30	
SL-35H	30 - 120	35	
SLH-20	30 - 120	20	Karabiner
SLM-12	30 - 120	12	
SLM-15	30 - 120	15	



SL



SLM



SLG

FOR OBJECT-USE

Model	Capacity (kg)	Rope Length (m)
SLG-100A	100	12.0
SLG-250-6	250	6.0
SLG-250-12	250	12.0
SLG-500	500	18.5

SLIP RING

Supply power and signal to rotate equipment.

Transit power and signal to equipment with rotation such as filling machine, auto-packing machine, game machine etc. The compact design enables easy handling and longer life.

SRP-CN4-F

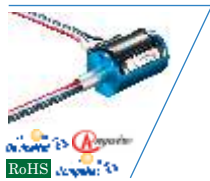

SRP-3003

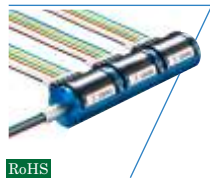

SRP-DN5



SRP-CL4H



SRP-CL4



SRP-10003



SRP-ML3



SRP-13575

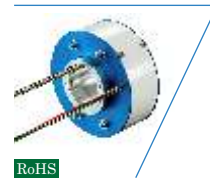

SR series



SR series

